

Compact Ring-Torsion Load Cells RTN



- PTB & OIML approved as suitable for trade use (up to 5000 d and 75010 d in case of multi-divisional scales)
- High accuracy, even for very small utilisation ranges (down to 15% in case of trade use according to OIML)
- High output signal and, thus, high-resolution of useful signal range
- Low power consumption allows realisation of multi-scale systems with simple evaluation electronics
- Protection to EEx ib IIC T 6 for use in explosion hazardous areas
- Protection class IP 68

Application

Acting as a transducer, the load cell converts the mechanical input signal, the load, proportionally into the electrical output voltage.

The consistent optimization of the ring-torsion load cells offers additional advantages:

- The extremely low headroom simplifies the use in almost all weighing applications.
- The sturdy design enables easy transport, installation, and operation, even under very harsh environmental conditions (e.g. aggressive media, interfering forces, or extreme temperatures)

Construction

- Hermetically sealed due to laser welding; protection class IP 68
- High corrosion protection due to the use of electrolytically polished stainless steel
- All electrical components are inside the load cell and are thus optimally protected
- The high-quality, sturdy connection cable is lead radially into the load cell
- The RTN load cells are compatible with earlier ring-torsion load cells if our adapter kits are used

Functions

- High measuring sensitivity
- High repeatability
- High long-term stability and, thus, continuing and consistently high accuracy
- Minimal effect on accuracy by side forces
- High reliability and availability, even in case of unavoidable shock loads, constraining forces or electrical interferences
- Integral excessive voltage protection
- Moment-free load input/output due to direct, vertical force flow

RTN 1 t – 4.7 t

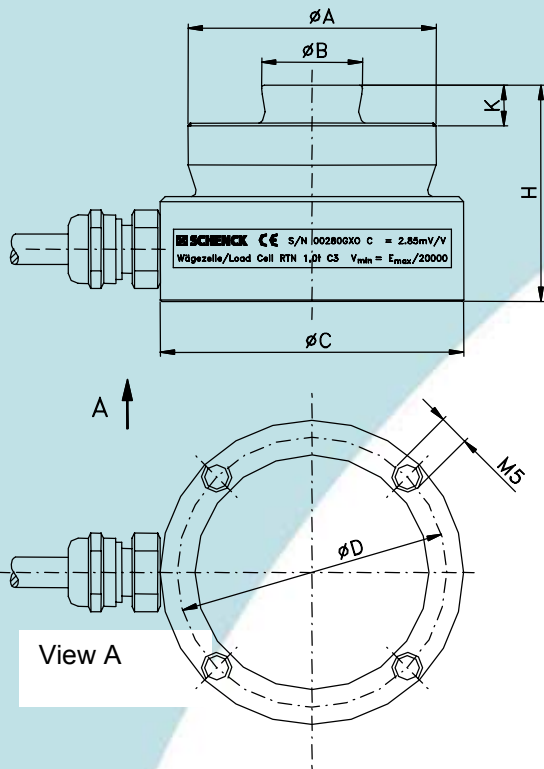

RTN 10 t - 470 t

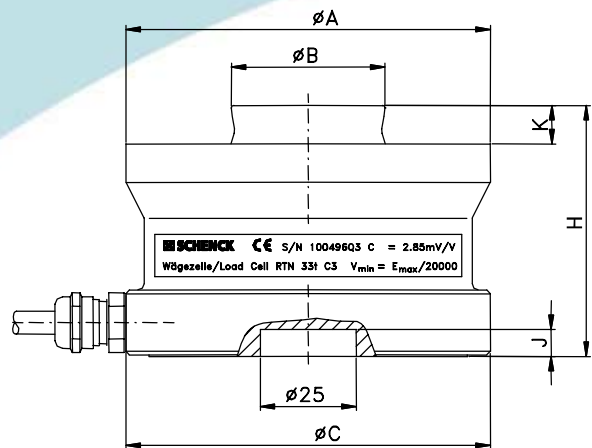

Technical Data

Rated Capacity E_{max} t	Limit Load L_l t	Rupture Load L_d t	Nominal displacement h_n mm	Dead weight kg
1	1.7	4	0.13	0.6
2.2	4	9	0.12	0.6
4.7	8	19	0.12	0.7
10	17	40	0.17	1.2
15	28	60	0.18	1.3
22	38	90	0.21	1.3
33	58	130	0.25	2.1
47	80	190	0.33	4.3
68	120	270	0.35	4.8
100	170	400	0.45	7.0
150	250	600	0.57	8.6
220	380	900	0.67	22.0
330	580	1200	0.85	29.0
470	700	1500	1.00	50.0

Dimensions

Type RTN	Dimensions (mm)						
	A	B	C	D	H	K	J
1 t	49	20	60	53	43	7.5	-
2.2 t	49	20	60	53	43	7.5	-
4.7 t	49	20	60	53	43	7.5	-
10 t	73	30	75	-	50	6.5	7
15 t	75	30	75	-	50	6.5	7
22 t	75	30	75	-	50	6.5	7
33 t	95	40	95	-	65	10	7
47 t	130	60	130	-	75	14	7
68 t	130	60	130	-	85	14	7
100 t	150	70	150	-	90	16	7
150 t	150	70	150	-	100	16	7
220 t	225	100	225	-	130	24	10
330 t	225	100	225	-	145	24	10
470 t	270	120	270	-	170	28	10

Admissible static side load $L_q = 0.5 (E_{max} - 0.8 L_z)$, but no higher than $L_{qmax} = 0.3 E_{max}$; E_{max} = rated capacity;
 L_z = load in measuring direction

Technical Data

Rated capacity	E_{max}	1 t – 470 t		1 t – 100 t		
Accurate class		0.05	C3	C5	C4 Mi 7.5	Reference
Sensitivity	C_n	2,85 mV/V \pm 2,85 μ V/V				
Combined error	F_{comb}	0.05 %	0.02 %	0.01 %	0.013 %	C_n
Minimum dead load output return	F_{dr}	\pm 0.03 %	\pm 0.016 %	\pm 0.01 %	\pm 0.006 %	C_n
Creep (30 m)	F_{cr}	\pm 0.04 %	\pm 0.024 %	\pm 0.014 %	\pm 0.009 %	C_n
Temperature effect on zero sensitivity	TK_0	\pm 0.03 % \pm 0.05 %	\pm 0.007 % \pm 0.02 %	\pm 0.0058 % \pm 0.02 %	\pm 0.0058 % \pm 0.02 %	C_n, B_{tn} C_n, B_{tu}
Temperature effect on sensitivity	TK_c	\pm 0.05 % \pm 0.07 %	\pm 0.008 % \pm 0.02 %	\pm 0.0062 % \pm 0.02 %	\pm 0.007 % \pm 0.02 %	C_n, B_{tn} C_n, B_{tu}
Maximum number of load cell intervalls	n_{LC}		3000	5000	4000	
For multi-divisional scales:	Z				7500	
Minimum load cell verification intervall	V_{min}		$E_{max}/20000$	$E_{max}/24000$		
Min. utilisation range	B_{amin}		15 %	20.8 %	16.7 % 31.2 %	E_{max}
Max. utilisation range	B_{amax}	$B_{amax} = E_{max}$				
Input resistance	R_e	4450 Ω \pm 100 Ω				t_r
Output resistance	R_a	4010 Ω \pm 2 Ω	4010 Ω \pm 0.5 Ω			t_r
Zero signal	S_0	\pm 1%				C_n
Max. supply voltage	U_{smax}	60V				
Nominal temperature range	B_{tn}	-10°C to +40°C				
Service temperature range	B_{tu}	-40°C to +80°C, Option to +110°C				
Reference temperature	T_r	22°C				
Storage temperature range	B_{ts}	-50°C to +85°C				
Protection class		IP 68				
Cable specification		Special silicone RAL 7000 (grey) \varnothing 6.5, -30°C to +150°C, Length 5 m for RTN 1-15 t and RTN 150-470 t Length 12 m bei RTN 22 t und RTN 47 - 100 t Length 15 m to RTN 33 t				
Colour code		Black: input + / blue: input - Red: output + / white: output - Green-yellow: screening				
Material		Stainless steel				
Corrosion protection		see Spec Sheet DDP 8483 "Chemical Resistant of RT Load Cells"				

Order No.

Variants	Accuracy class			
	0.05	C3	C5	C4Mi 7.5
RTN 1 t	D726173.04	D726173.02	D726173.10	D726173.14
RTN 2.2 t	D726174.04	D726174.02	D726174.10	D726174.14
RTN 4.7 t	D726175.04	D726175.02	D726175.10	D726175.14
RTN 10 t	D726176.04	D726176.02	D726176.10	D726176.14
RTN 15 t	D726177.04	D726177.02	D726177.10	D726177.14
RTN 22 t	D724781.04	D724781.02	D724781.10	D724781.14
RTN 33 t	D724754.04	D724754.02	D724754.10	D724754.14
RTN 47 t	D724782.04	D724782.02	D724782.10	D724782.14
RTN 68 t	D724783.04	D724783.02	D724783.10	D724783.14
RTN 100 t	D724784.04	D724784.02	D724784.10	D724784.14
RTN 150 t	D726178.04	D726178.02		
RTN 220 t	D726179.04	D726179.02		
RTN 330 t	D726180.04	D726180.02		
RTN 470 t	D726181.04	D726181.02		

Order No. Version ATEX zone 1 (Gas-Ex category II 2 G; EEx ia IIC T4 / T6 to ATEX guideline 94/9/EG)

Ex-Variants	Accuracy class			
	0.05 "Ex-zone 1"	C3 "Ex1-zone 1"	C5 "Ex-zone 1"	C4Mi 7.5 "Ex-zone 1"
RTN 1 t	D726173.03	D726173.01	D726173.09	D726173.13
RTN 2.2 t	D726174.03	D726174.01	D726174.09	D726174.13
RTN 4.7 t	D726175.03	D726175.01	D726175.09	D726175.13
RTN 10 t	D726176.03	D726176.01	D726176.09	D726176.13
RTN 15 t	D726177.03	D726177.01	D726177.09	D726177.13
RTN 22 t	D724781.03	D724781.01	D724781.09	D724781.13
RTN 33 t	D724754.03	D724754.01	D724754.09	D724754.13
RTN 47 t	D724782.03	D724782.01	D724782.09	D724782.13
RTN 68 t	D724783.03	D724783.01	D724783.09	D724783.13
RTN 100 t	D724784.03	D724784.01	D724784.09	D724784.13
RTN 150 t	D726178.03	D726178.01		
RTN 220 t	D726179.03	D726179.01		
RTN 330 t	D726180.03	D726180.01		
RTN 470 t	D726181.03	D726181.01		

Example for ordering: Rated Capacity 47t, accuracy class C5: Variant RTN 47t C5-
Order No.: D 724782.10

*) zone classification according to ATEX
variants for other zones (2, 21, 22), please enquire

Option:

Variant for service temperature
range of up to 110°C
Customized cable length
Special corrosion protection
Connection cable PVC

Accessories:

Elastomer mount, Compact
mounts, Pendulum mounts,
Fixed bearing



Measuring and Process Systems
SCHENCK PROCESS GmbH
D-64273 Darmstadt
Phone: +49 (0) 61 51-32 10 28
Fax: +49 (0) 61 51-32 11 72
E-Mail: bvk.process@schenck.net
www.schenck-process.net

The Group

Keep in Motion